

nexVortex Microsoft Teams Information

TUESDAY, NOVEMBER 5th, 2019 at 2pm EST

Key Slides from Webinar

Mike Nowak
mnowak@nexVortex.com



Know anyone else who should attend this Webinar?

- Next Teams Webinar - November 7th at 2pm EST

Register through Landing Page

https://www.nexvortex.com/ms_teams_webinar/

Or email partners@nexVortex.com

- Karis Law E911 Webinar - November 11th at 2pm EST

Register through Landing Page

<https://www.nexvortex.com/e911-education>

Or email partners@nexVortex.com

TODAY'S PRESENTER



MIKE NOWAK

Vice President of Sales (GRAND RAPIDS, MI)

✓ You can contact him at mnowak@nexVortex.com or 616.259.0601

COMPANY SNAPSHOT

- ✓ 13 years delivering commercial service



Deloitte.
Technology Fast500

- ✓ Own, Operate, & Develop Call Processing, Portals, and Billing Platform

- ✓ History of Interop Testing with PBX Platforms and SD WAN Providers

- ✓ “Sell With” Channel Program



Office 365

- ✓ 1.2 billion users of Microsoft Office
- ✓ 155,000,000 active business users of 365
- ✓ An analysis of over 135,000 organizations found that ~56% of companies were using Office 365 in 2018 – up from ~35% in 2016



 Office 365



Microsoft Teams



Teams is a unified communications platform that combines chat, email, video, meetings, file storage, and application integration.



Teams is a Feature, Not a Product

Microsoft Teams Rapid Growth

Microsoft Teams

Celebrating 2 years of continued growth



500,000+

More than 500,000 organizations use Teams



91%

91 Fortune 100 companies use Teams



44+

In 181 markets with support for 44 languages and growing



10,000+

150 organizations have 10,000 or more active users

Teams IM Client

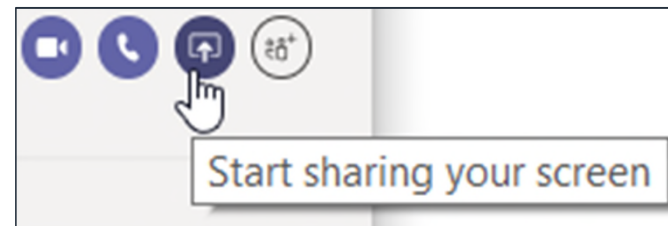
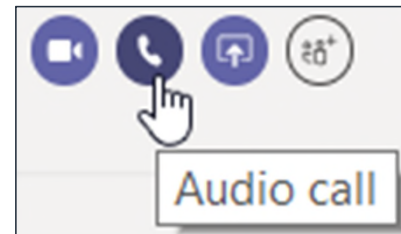
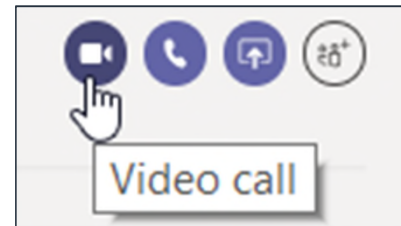
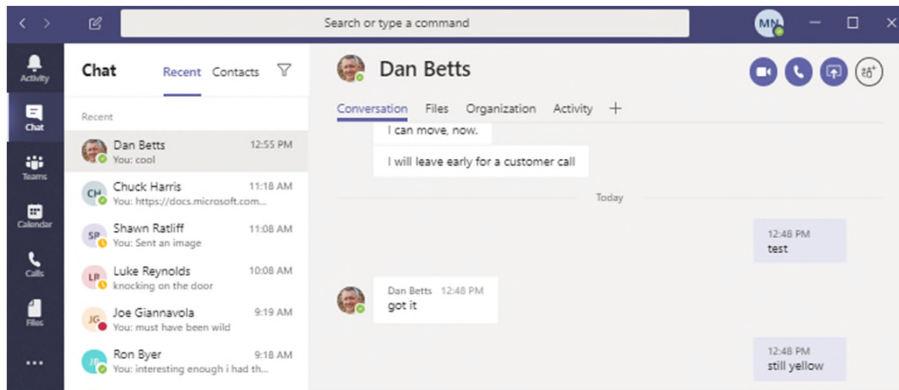

CONFIDENTIAL
nexVortex, Inc. ©2019

Teams to Teams User Calls

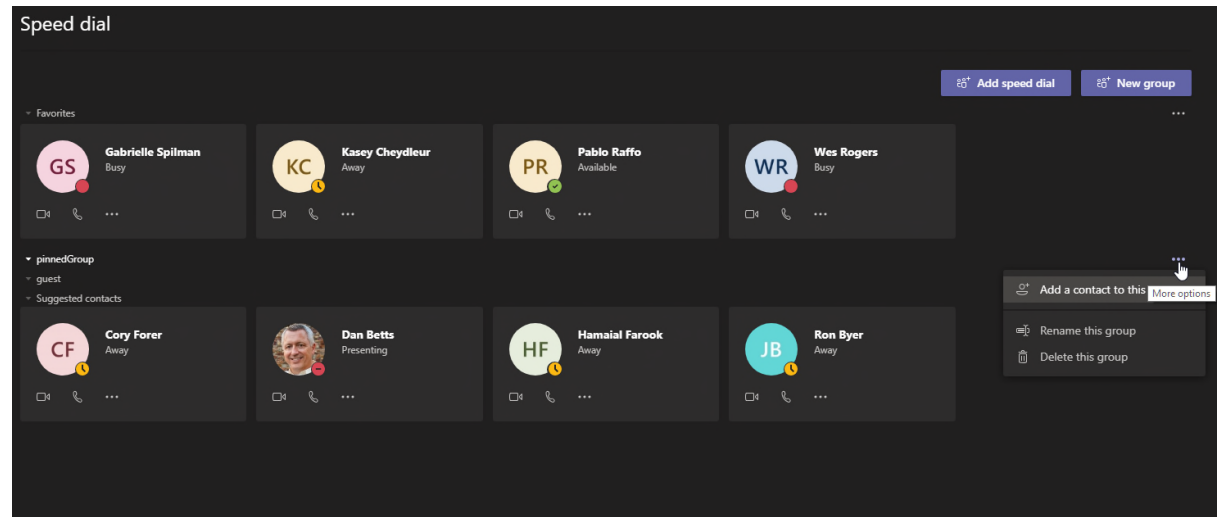
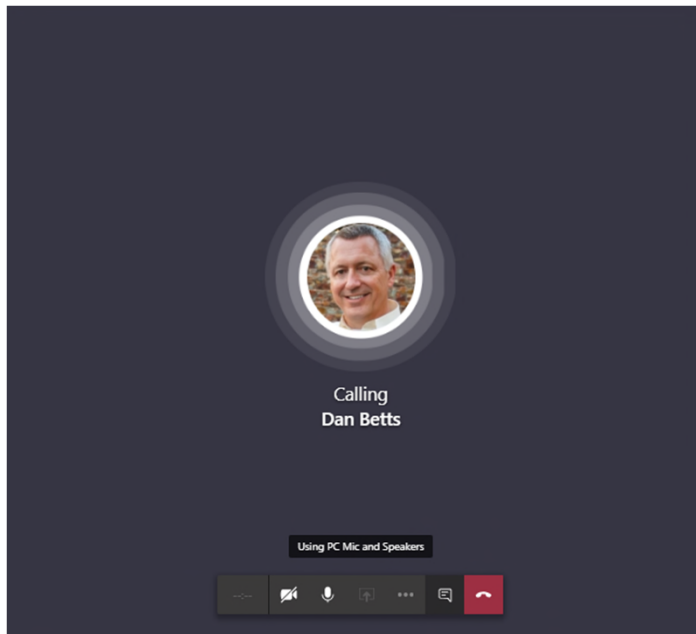

Teams Federations

✓ Open Federations/External Access

✓ Guest Federations

- Limits based on your Azure AD licensing
 - Usually 5 Guests per Employee
- No License required
- Permissions can be managed by Teams Admin

Teams allows those belonging to other organizations to connect via chat, calls, video calls, screen share and share files.



Microsoft Phone System

- ✓ Phone System represents the technology for enabling PBX capabilities in the Office 365 Cloud.
- ✓ Enables Teams users to place/receive outside calls.
- ✓ Contains other features such as:
 - Auto-Attendants/Call Queues
 - Call Forwarding
 - Caller ID
 - Call Routing



Supported Phones & Devices

Microsoft Teams Devices

Room Systems



Phones must be loaded with Teams Firmware and have Microsoft Device License

Room Phones



Personal Devices



Source: dmunified Nov 2018

Office 365 Licensing & Phone System



Step 1 = 365 Licenses

- Customer must have E class license. Each user can have a different license type.

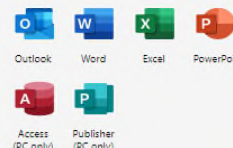
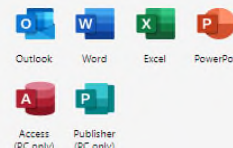
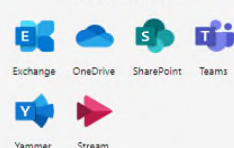
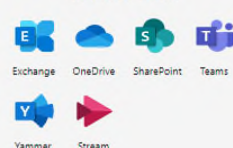
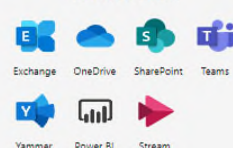
Office 365 E1	Office 365 E3	Office 365 E5
<p>\$8.00 user/month (annual commitment)</p> <p>Buy now</p> <p>Learn more ></p>	<p>\$20.00 user/month (annual commitment)</p> <p>Buy now</p> <p>Try for free ></p> <p>Learn more ></p>	<p>\$35.00 user/month (annual commitment)</p> <p>Buy now</p> <p>Try for free ></p> <p>Contact sales ></p> <p>Learn more ></p>
<p>Business services—email, file storage and sharing, Office Online, meetings and IM, and more. Office applications not included.</p> <p>Office applications included</p> <p>(Not included)</p>	<p>All the features of ProPlus and Office 365 E1 plus security and compliance tools, such as legal hold, data loss prevention, and more.</p> <p>Office applications included</p>  <p>Outlook Word Excel PowerPoint Access (PC only) Publisher (PC only)</p>	<p>All the features of Office 365 E3 plus advanced security, analytics, and voice capabilities.</p> <p>Office applications included</p>  <p>Outlook Word Excel PowerPoint Access (PC only) Publisher (PC only)</p>
<p>Services included</p>  <p>Exchange OneDrive SharePoint Teams Yammer Stream</p>	<p>Services included</p>  <p>Exchange OneDrive SharePoint Teams Yammer Stream</p>	<p>Services included</p>  <p>Exchange OneDrive SharePoint Teams Yammer Power BI Stream</p>

MS Teams Phone System

Step 2 = Phone System License

- Microsoft customers must have “Phone System” licenses for calling capabilities beyond Teams user to user.
 - E1: \$8.00 extra per mo – per user
 - E3: \$8.00 extra per mo – per user
 - E5: Included
- User will also need a calling plan or Direct Routing PTSN access provider.

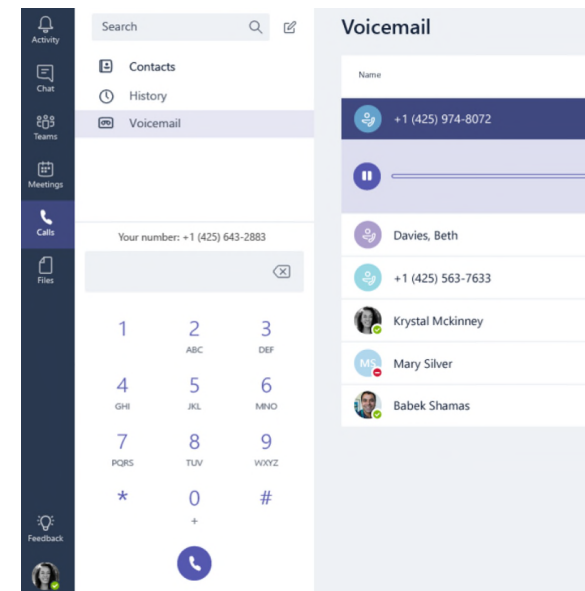

PSTN ACCESS



Step 3 = Direct Routing or Microsoft Calling Plan

Direct Routing allows a customer to choose their telecom provider to enable their users to make and receive PSTN calls in Teams.

Or

Microsoft Calling Plans can be purchased for each user.



PSTN ACCESS: MICROSOFT CALLING PLANS

Commonly Used Microsoft Calling Plans

Domestic 120 Minutes per user	\$6 per Month
Domestic 3000 Minutes per user	\$12 per Month
International: Domestic 3000, 600 International	\$24 per Month

Considerations

- Per User Plans
- No 3rd party PBX Trunk Sharing
- Microsoft Number Porting, Billing & Support
- Microsoft Promotes Direct Routing



PSTN ACCESS: Direct Routing

✓ What is Direct Routing?

- Direct Routing lets you connect a supported, customer provided SBC to Microsoft Phone System.
- nexVortex can connect via the use of an AudioCodes SBC or alternative certified SBC.

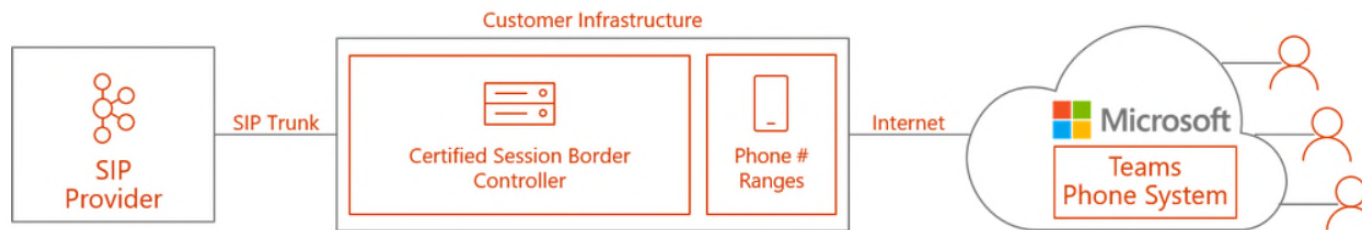

AudioCodes Certified

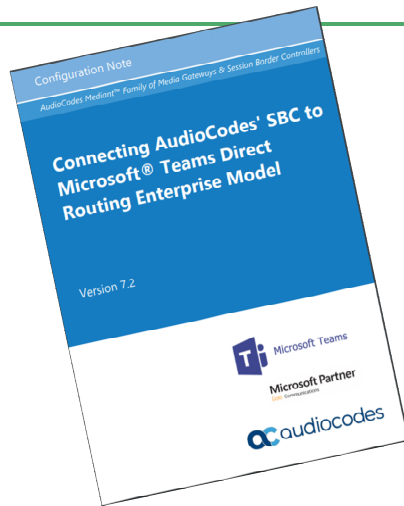

nV is certified & tested with both AudioCodes physical and virtual SBCs.

AudioCodes Hardware (Mediant Series)

Comes preconfigured for a set number of licenses, can be upgraded with the purchase of additional software.



AudioCodes VE SBC
Purchased **directly** from the Azure Marketplace. Provides direct routing capability without the need for hardware.



PSTN Access: nexVortex Direct Routing Plans



nexVortex Sharable Trunk Plans

\$19.99 per sharable Trunk

- Includes Unlimited Minute Calling and DID with Disaster Recovery
- Additional DIDs, Toll Free, E911 registered locations can be added
- International Calling can be activated through portal
- Pricing is based on 20 or more trunks on 3 year term

Audiocodes



Virtual SBC



On Prem PBX



Avaya

Sharable Trunks

nexVortex trunks to be shared
Across multiple SBCs or SBCs &
PBXs

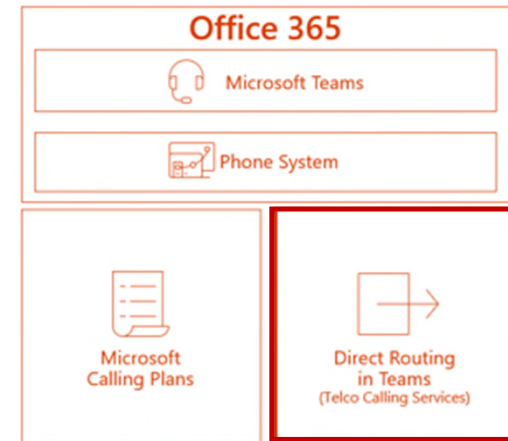

Microsoft Phone System Features



Whats Missing:

- *Advanced Call Routing*
- *Call Recording*
- *Contact Center Features*
- *Reporting*
- *Parking*
- *Intercom/Paging*
- *E911 Management*
- *Faxing*

According to Gartner: Teams telephony lacks APIs for contact center, CRM and attendant console integration. Hence, many Teams telephony customers must keep 10% to 20% of users on the legacy PBX platform.

Existing Phone System with Teams

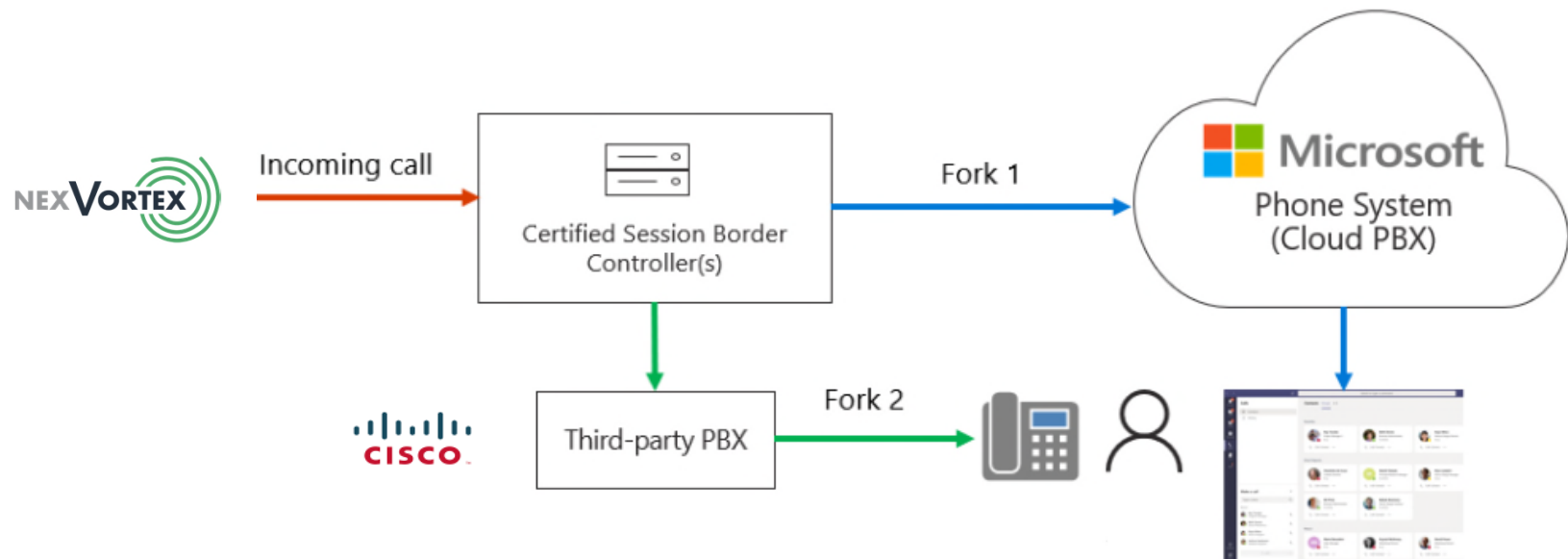

SBCs that support call forking can send calls to Teams Phone System or a certified/tested PBX.

nexVortex Trunk Sharing



Trunk Resources Shared



TRUNK RESOURCES SHARED

- ✓ Avoid Under-Utilization Waste
- ✓ Share Resources on Demand
- ✓ Autodetecting Failover

nexVortex Disaster Recovery & Routing Control

Autodetecting Disaster Recovery
Included Free with Every SIP Account

- Disaster recovery rules:**
- ✓ Individually preset by TN or Toll-Free Number
 - ✓ IP address, DNS, or phone number
 - ✓ Managed through our easy-to-use-portal

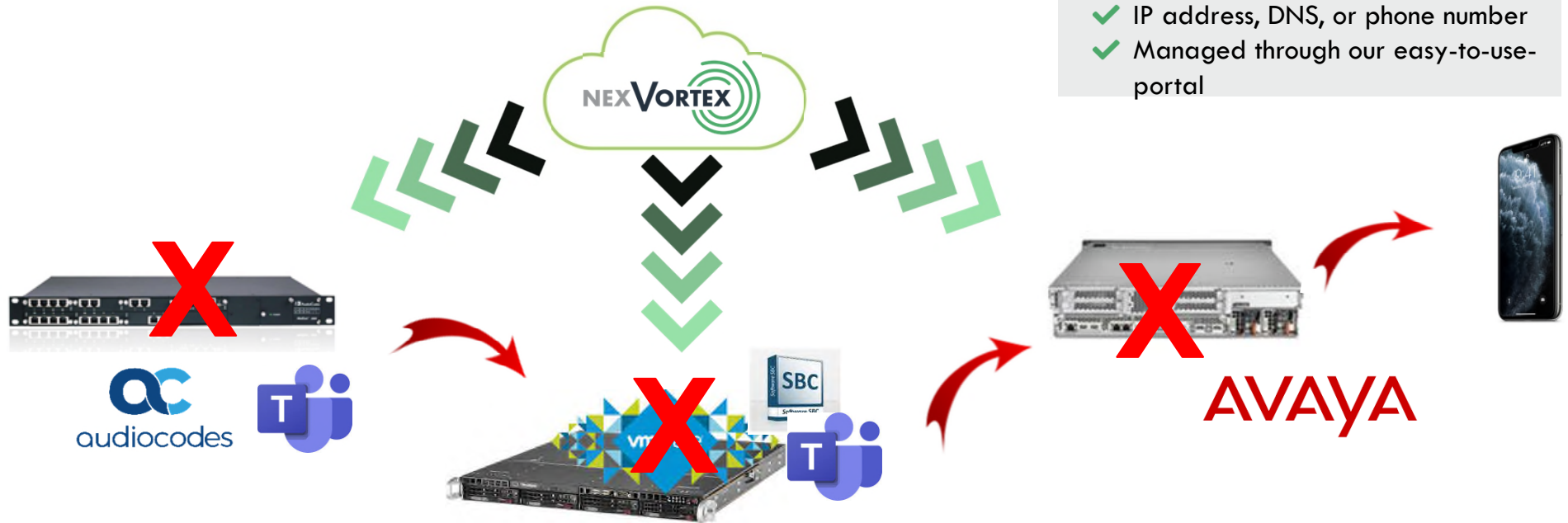

Autodetecting Disaster Recovery

AUTODETECTING

PRESET FAILOVER

WEB PORTAL CONTROL

FAILOVER TO PHONE #'S OR IP ADDRESSES

Settings > Disaster Recovery Routing

Disaster Recovery Routing, allows incoming calls to be forwarded to an alternate destination in the event that the call could not be delivered to the intended location due to a problem with your phone system or your internet access connection. Each number is individually configurable and you can specify up to three alternate locations. Each alternate location can be either a standard telephone number or an IP end point. For example, you can forward calls to your cell phone. (Note, calls routed back out to the traditional phone network will be treated as normal outbound calls for billing purposes).

To setup Disaster Recovery Routing for a number, click on the Edit icon to the far right for the number you want to setup. If you are entering a telephone number, please enter 1+10 digits. Sorry, no international numbers. If you are entering an IP destination, please enter in either 1) the dotted IP address of the destination system if it is using a static IP address, or 2) the text user name that the destination system is using to Register with our service if it is using a dynamic IP address.

You can remove all DR routes for a number by clicking on the Trash can to the far right.

To cancel this service, please go to **Order Services > Disaster Recovery Routing**.

Phone Number	1st Alternate Route	2nd Alternate Route	3rd Alternate Route
<input type="checkbox"/> 16162590602	66.23.136.140	contoso.com	17034392732
	IP Address	DNS	Cell Phone



nexVortex Teams Sweet Spots

- ✓ Those interested in a phased rollout or considering Teams in the future
 - Select a Future Proof Service
- ✓ Companies who are going to maintain an on-premise PBX with their Teams deployment
- ✓ Companies with both On-Prem & Virtual SBCs

nV TRUNK RESOURCES

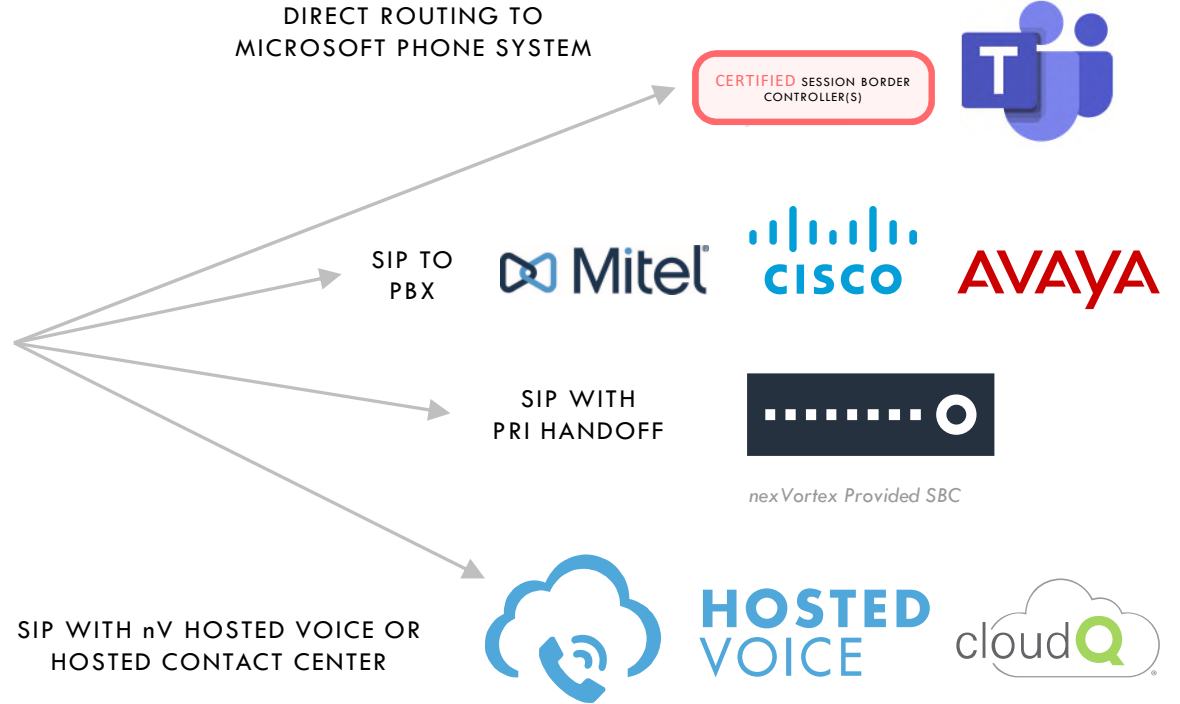

SUMMARY

- ✓ nexVortex reduces risk with future proof solutions such as the ability to start on one service with the ability to migrate to another later
 - ✓ Great fit for customers who want to Migrate to Teams over Time or run hybrid configurations
 - ✓ Advanced Voice Routing Capabilities that include trunk sharing, auto detecting disaster recovery and E911 capabilities
 - ✓ “Sell With” Program to help our Channel Partners design the appropriate solution
-

Thank You



www.nexVortex.com

An Uncommon Company

Sales@nexVortex.com

855.639.8888